

# EAGLE TUGS



## OPERATIONS MANUAL

VEHICLE TYPES: ALL TT MODELS





Read this manual in its entirety before putting your Eagle tow tractor into service. This manual contains important safety instructions. Improper usage or a failure to follow the safety requirements listed in this manual could result in severe injury or death.

# 1-1 Table of Contents

---

0-1	Safety Warning
1-1	Table of Contents
2-1	Revision Sheet
3	Introduction
3-1	Welcome
3-2	Contact Info
3-3	Warranty
3-4	Proper Use
3-5	Vehicle Weights, Performance, and Specifications
4	Putting the Tow Tractor Into Service
4-1	Unpacking/Setting Up
4-2	Fuel Requirements
5	Instructions for Safe Use
5-1	General Safety Guidelines
5-2	Operator Requirements
5-2	Operator Workstation
5-3	Pre-Operation Inspection
5-4	Sauer Danfoss Display Panel
5-5	Instrumentation
5-6	Controls
5-7	Starting/Shutdown
5-8	Transmission
5-8	Braking
5-9	Parking
6	Instructions for safe towing/pushing a load
6-1	Towing
6-1	Pushing
7	Instructions for safe handling
7-1	Emergency Towing
7-2	Tie-Down Procedure

- 8 Instructions for safe maintenance
  - 8-1 Maintenance Operator Requirements
  - 8-2 General Safety Guidelines
  - 8-3 Preventative Maintenance Schedules
  - 8-4 Daily operator responsibilities
    - Proper Fluid Checks
- 9 CE Conformance
  - 9-1 Declaration of Conformance

## **Original Instructions**

## 2-1 Revision Sheet

---

### Revision History

Rev Number	Description	Affected Section(s)	Date
REV00	Initial Release	All	1/11/09
REV01	Wording	All	2/27/10
REV02	Warranty Statement & Vehicle Weight and Performance	3	01/06/12

### Welcome

Welcome to the growing family of EAGLE tractor operators. The tractor was built with the operator's safety, comfort and ease of operation in mind. We hope you agree and enjoy your EAGLE experience.

### Purpose & Use of Manual

This manual is designed as a quick guide to familiarize you with the correct and safe operation of your Eagle vehicle as well as to inform you of the preventative maintenance and servicing recommendations of the manufacturer.

Your EAGLE vehicle was designed to do very specific tasks. For that reason, it will look, feel, drive and function differently than over-the-road trucks and automobiles, as well as various other types of vocational vehicles. It is the operator's responsibility to operate this equipment in a safe and prudent (good sound judgment) manner. Be alert, your and other's safety is involved.

The descriptions and specifications contained in this manual were in effect at the time the manual was printed. EAGLE TUGS reserves the right to discontinue models at any time and/or to change specifications, designs or components used without notice and without incurring obligations.

### Contact Information

#### **Corporate Offices**

*Sales, Support, Customer Service*

Eagle Industrial Truck

26111 Northline Rd

Taylor, MI 48180

USA

(734) 442-1000 — (800) 671-0431

#### **Website**

[www.eagletugs.com](http://www.eagletugs.com) contains useful sales and service information. Please refer to this website for the latest revision of this and all other manuals.

#### **Email Addresses**

Customer Service [customerservice@eagletugs.com](mailto:customerservice@eagletugs.com)

Parts Department [parts@eagletugs.com](mailto:parts@eagletugs.com)

Technical Support [support@eagletugs.com](mailto:support@eagletugs.com)

Sales Department [sales@eagletugs.com](mailto:sales@eagletugs.com)



Warranty

Please read warranty information carefully.

Before contacting Eagle Industrial Truck for any warranty issue please have the following information ready:

Truck Model	
Truck Serial Number	
Engine Type	
Engine Make	
Engine Serial Number	
Hours Reading	

All information can be found on the data plate located beside the driver seat with the exception of the hours which can be read using the H30 display or the hour meter on the dash.

Warranty Registration

Vehicles powered by a Yanmar engine should register the engine by entering the required information into the Customer registration screen found on Yanmar's website at <http://www.yanmar.co.jp>. Vehicles powered by a Wisconsin Motors TME27 engine should contact Eagle directly if prior to warranty work being performed for information on the nearest Wisconsin Motors distributor in your area. Warranty registration for your Eagle tractor can be completed at our website [www.eagletugs.com](http://www.eagletugs.com).

Tires

For pneumatic tires, contact your nearest Power King (Kelly-Springfield) brand dealer who will adjust your claim based on the remaining tread wear as a percent of total new tread.

For solid tires, contact Eagle directly.

Battery

In the U.S. and Canada, call 1-888-823-0954 or 1-877-255-2287

**3-Year Limited Warranty Information\***

The Eagle Tugs (Eagle) 3-Year Warranty covers all TT-series, eTT-series, XL-series, eXL-series and USATS tow tractors, used in aviation applications. Eagle Tugs warrants that these tractors will be free from defects in material and workmanship for a period of 3 years or 3,000 operating hours, with the exception of the electrical system (see electrical component warranty below), from date of delivery to the first customer (or first use), whichever comes first. Written notice of any claimed defect must be given to Eagle within the warranty period and within thirty (30) days after such defect is discovered. Liability under this warranty is limited to either replacing or repairing, at Eagle's election, any part or parts deemed defective after examination by Eagle or an Authorized Service Representative. Any Eagle tractor or any of its parts returned by the customer to Eagle or an Authorized Service Representative via prepaid transportation, and which is found to be defective, will be repaired or replaced and returned to the customer prepaid. On the other hand, should a part be found not defective, inspection and handling charges may be charged to the customer or Authorized Service Representative by Eagle.

**Electrical Component Warranty:** Electrical components including but not limited to display, starters, alternators and electric fans shall be covered under the respective original manufacturers warranty for each individual component. Copies of the respective warranties are available upon request.

This warranty does not extend to the tires, batteries, and battery chargers as these are warranted directly to the user by their respective manufacturer and not by Eagle or an Authorized Service Representative.

This warranty does not apply to any Eagle tow tractor, or component part(s) that have been subjected to misuse, accident, vandalism, environmental conditions, improper handling or application, maintenance neglect, including lack of lubricants or fluids; nor does it extend to the Eagle tow tractor and/or parts which have been repaired or altered outside of Eagle's plant or the facility of an Authorized Service Representative without the permission of Eagle.

This warranty does not apply to routine maintenance or wearable parts of the Eagle tow tractor such as filters, seals, plugs, hoses, belts, brake pads or shoes, light bulbs, fuses or similar items. Moreover, this warranty does not extend beyond its original term for any Eagle tow tractor or part replaced or repaired under warranty.

This warranty does not cover or provide credit for the following: tractor rental or other substitute equipment; lodging; loss of time, income, sales or profits; loss of the use of tractor; telephone calls or communication expense; lift truck; storage fees; injury or death to persons or damage or destruction of property; or consequential, incidental or punitive damages.

**Labor Allowance:** A labor allowance may be issued upon request at Eagle's discretion. Allowable labor hours and a per hour labor rate will be determined by Eagle according to reasonable automotive standards.

**Warranty Claim Procedure:** When a warranty situation arises, it is essential that the customer contact Eagle's Warranty Department at +1 734-442-1000. The customer will need to provide Eagle with the tow tractor serial number and engine hours. A customer service representative will analyze the problem and determine the next steps. In many cases Eagle's technical support personnel will be able to analyze the problem and recommend adjustments that will solve the problem and reduce down time. If further service is required, an Eagle customer service representative will work with customer personnel to arrange a service provider and/or parts be sent to your facility for the repair as quickly as possible.

EXCEPT AS SET FORTH ABOVE, ALL WARRANTIES, CONDITIONS, REPRESENTATIONS, INDEMNITIES AND GUARANTEES, EXPRESS OR IMPLIED, WHETHER ARISING BY STATUTE, CUSTOM OF TRADE OR UNDER ORAL OR WRITTEN STATEMENTS MADE BY OR ON BEHALF OF EAGLE NEGOTIATIONS WITH CUSTOMER, DISTRIBUTOR, DEALER OR ANY REPRESENTATIVE, ARE HEREBY OVERWRITTEN AND EXCLUDED, AND NO LIABILITY SHALL ATTACH TO EAGLE, EITHER IN CONTRACT OR IN TORT, OR STRICT LIABILITY IN TORT, FOR ANY DAMAGE TO PROPERTY, LOSS OF PROFITS, DAMAGES, COSTS, CHARGES, LIABILITY OR EXPENSES, WHETHER DIRECT OR INDIRECT, CONSEQUENTIAL OR OTHERWISE, WHICH ARISE OUT OF OR IN CONNECTION WITH THE SALE OR USE OF ANY EAGLE MACHINE OR THE SUPPLY OF SERVICES.

SUBJECT TO CHANGE WITHOUT NOTICE

Please check our website [www.eagletugs.com](http://www.eagletugs.com) periodically for service bulletins and manual updates.

\*Note - The Eagle Tugs 3-Year Warranty covers TT-series, eTT-series, XL-series, eXL-series and USATS tow tractors used in aviation applications. All MTT and RTT-series, and Transit Pro tow tractors, and all Eagle models which are used in industrial applications, are covered under the Eagle **Standard Warranty** of 1 Year or 2,000 hours. Eagle Bob Tails are covered under Ford Motor Company's Standard Warranty for each respective Ford truck model.

**Standard Limited Warranty Information\***

The Eagle Tugs (EAGLE) Standard Warranty covers all MTT, RTT-series and Transit Pro tow tractors, as well as all Eagle tow tractor models used in industrial applications. Eagle Tugs warrants that these tractors will be free from defects in material and workmanship for a period of 1 year or 2,000 operating hours, with the exception of the electrical system (see electrical component warranty below), from date of delivery to the first customer (or first use), whichever comes first. Written notice of any claimed defect must be given to Eagle within the warranty period and within thirty (30) days after such defect is discovered. Liability under this warranty is limited to either replacing or repairing, at Eagle's election, any part or parts deemed defective after examination by Eagle or an Authorized Service Representative. Any Eagle tractor or any of its parts returned by the customer to Eagle or an Authorized Service Representative via prepaid transportation, and which is found to be defective, will be repaired or replaced and returned to the customer prepaid. On the other hand, should a part be found not defective, inspection and handling charges may be charged to the customer or Authorized Service Representative by Eagle.

**Electrical Component Warranty:** Electrical components including but not limited to display, starters, alternators and electric fans shall be covered under the respective original manufacturers warranty for each individual component. Copies of the respective warranties are available upon request.

This warranty does not extend to the tires, batteries, and battery chargers as these are warranted directly to the user by their respective manufacturer and not by Eagle or an Authorized Service Representative.

This warranty does not apply to any Eagle tow tractor, or component part(s) that have been subjected to misuse, accident, vandalism, environmental conditions, improper handling or application, maintenance neglect, including lack of lubricants or fluids; nor does it extend to the Eagle tow tractor and/or parts which have been repaired or altered outside of Eagle's plant or the facility of an Authorized Service Representative without the permission of Eagle.

This warranty does not apply to routine maintenance or wearable parts of the Eagle tow tractor such as filters, seals, plugs, hoses, belts, brake pads or shoes, light bulbs, fuses or similar items. Moreover, this warranty does not extend beyond its original term for any Eagle tow tractor or part replaced or repaired under warranty.

This warranty does not cover or provide credit for the following: tractor rental or other substitute equipment; lodging; loss of time, income, sales or profits; loss of the use of tractor; telephone calls or communication expense; lift truck; storage fees; injury or death to persons or damage or destruction of property; or consequential, incidental or punitive damages.

**Labor Allowance:** A labor allowance may be issued upon request at Eagle's discretion. Allowable labor hours and a per hour labor rate will be determined by Eagle according to reasonable automotive standards.

**Warranty Claim Procedure:** When a warranty situation arises, it is essential that the customer contact Eagle's Warranty Department at +1 734-442-1000. The customer will need to provide Eagle with the tow tractor serial number and engine hours. A customer service representative will analyze the problem and determine the next steps. In many cases Eagle's technical support personnel will be able to analyze the problem and recommend adjustments that will solve the problem and reduce down time. If further service is required, an Eagle customer service representative will work with customer personnel to arrange a service provider and/or parts be sent to your facility for the repair as quickly as possible.

EXCEPT AS SET FORTH ABOVE, ALL WARRANTIES, CONDITIONS, REPRESENTATIONS, INDEMNITIES AND GUARANTEES, EXPRESS OR IMPLIED, WHETHER ARISING BY STATUTE, CUSTOM OF TRADE OR UNDER ORAL OR WRITTEN STATEMENTS MADE BY OR ON BEHALF OF EAGLE NEGOTIATIONS WITH CUSTOMER, DISTRIBUTOR, DEALER OR ANY REPRESENTATIVE, ARE HEREBY OVERRITTEN AND EXCLUDED, AND NO LIABILITY SHALL ATTACH TO EAGLE, EITHER IN CONTRACT OR IN TORT, OR STRICT LIABILITY IN TORT, FOR ANY DAMAGE TO PROPERTY, LOSS OF PROFITS, DAMAGES, COSTS, CHARGES, LIABILITY OR EXPENSES, WHETHER DIRECT OR INDIRECT, CONSEQUENTIAL OR OTHERWISE, WHICH ARISE OUT OF OR IN CONNECTION WITH THE SALE OR USE OF ANY EAGLE MACHINE OR THE SUPPLY OF SERVICES.

SUBJECT TO CHANGE WITHOUT NOTICE

Please check our website [www.eagletugs.com](http://www.eagletugs.com) periodically for service bulletins and manual updates.

\*Note - The Eagle Tugs **3-Year Warranty** covers TT-series, eTT-series, XL-series, eXL-series and USATS tow tractors which are used in aviation applications. All MTT and RTT-series, and Transit Pro models, as well as all Eagle tow tractor models which are used in industrial applications, are covered under the Eagle Standard Warranty of 1 Year or 2,000 hours. Eagle Bob Tails are covered under Ford Motor Company's Standard Warranty for each respective Ford truck model.

### Proper Use of TT Series Tow Tractors

The TT line of tow tractors is designed to be an aircraft tow tractor. When used properly in this application, the TT line of tow tractors will provide years of safe operation. The following activities fall within the approved and anticipated usage:

- Aircraft Towing
- Aircraft Push-back
- Travel on improved surfaces with minimal slope

Never misuse the tow tractor. The tractor has been designed with aircraft towing as the intended usage. Never do any of the following with the tow tractor:

- “Horseplay”
- Racing
- Turn at excessive speed
- Off-road travel or travel on unimproved surfaces
- Drive crossways on a slope or turn on a slope

Vehicle Weights and Performance

Model Number	Year of Manuf.	Mass (lb/N)		Rated Draw Bar Pull, DBP (lb/N)		Rated Vertical Hitch Load (lb/N)	
TT4	2008	6,700	29,800	4,000	17,800	500	2,200
TT4 AWD	2008	4,500	20,000	4,000	17,800	500	2,200
TT5	2008	8,300	36,900	5,000	22,200	500	2,200
TT5 AWD	2008	5,600	24,900	5,000	22,200	500	2,200
TT6	2008	10,000	44,500	6,000	26,700	500	2,200
TT6 AWD	2008	6,700	29,800	6,000	26,700	500	2,200
TT8 AWD	2008	8,900	39,600	8,000	35,600	500	2,200
TT10 AWD	2008	11,100	49,400	10,000	44,500	500	2,200
TT12 AWD	2008	13,300	59,200	12,000	53,400	500	2,200

Engine	Power (hp/kW)		Torque (ft-lb/Nm)	
Wiscon TME27 Gas	80	60	162	220
Wiscon TME27 LPG	80	60	162	220
Yanmar 4TNV98 Diesel	67	50	186	252
Yanmar 4TNV98T Diesel	83	62	234	317

Operator Vibration Level Data

The operator interface vibration levels on the TT-series tug were tested by ISO / IEC 17025 accredited testing lab Kolano and Saha Engineers, Inc. of Waterford, MI, USA.

**Kolano and Saha Engineers, Inc.**  
Project No. 2008-193

**TABLE 1**  
**ACCELERATION VALUES**

Study Conducted for: **EAGLE TUGS**

<u>Measurement Location</u>	<u>Operating Condition</u>	<u>Result</u>
Floor	Engine idling	Values do not exceed 0.5 m/s <sup>2</sup>
Seat Bracket	Engine idling	0.57 m/s <sup>2</sup> at 33 Hz 0.57 m/s <sup>2</sup> at 67 Hz
Steering Wheel	Engine idling	Values do not exceed 2.5 m/s <sup>2</sup>
Floor	Engine at 2600 RPM	5.24 m/s <sup>2</sup> at 87 Hz Five peaks between 521 Hz and 652 Hz with a maximum of 2.01 m/s <sup>2</sup> at 587 Hz.
Seat Bracket	Engine at 2600 RPM	5.65 m/s <sup>2</sup> at 87 Hz 0.74 m/s <sup>2</sup> at 519 Hz 0.70 m/s <sup>2</sup> at 562 Hz
Steering Wheel	Engine at 2600 RPM	Values do not exceed 2.5 m/s <sup>2</sup>

Measurements were made at 1 Hz bandwidth from 0 to 1000 Hz.

The target values are supplied as a magnitude and do not state over which frequency range it is applicable.

Tests were performed November 14, 2008 on a Yanmar Model TT-8 Aircraft Tow Tractor.

Sound Level Data

The TT-series tow tractor emits the following sound levels:

Model	Peak dBA at Workstation	
	Cycling Throttle while Stationary	Full Throttle Moving
Yanmar 4TNV98 and 4TNV98T	95	94

The sound level test was performed in a open area on a flat asphalt surface. Readings were taken at the operator workstation, approximate ear height. The following are the test conditions:

SPL Meter:	Tandy, model 33-2055
Ambient Environment:	67 dBA
Temperature:	50°F / 10°C
Dewpoint:	37°F / 2°C
Humidity:	63%
Barometer:	30.28 in / 1025 hPa

EMC Data

Electromagnetic radiation and immunity were tested by Jacobs Engineering, at the Milford Proving Ground facility in Milford, MI, USA.

Electromagnetic Immunity:

Vehicle was subjected to a 60V/m electromagnetic field from 30MHz to 1000MHz. No effects were observed on the functionality or operation of the vehicle. This is in conformance with harmonized standard EN 12895:2000.

Electromagnetic Radiation:

The vehicle electromagnetic radiation was measured in accordance with harmonized standard EN 12895:2000 at frequencies from 30MHz to 1000MHz. All data was within limits deemed acceptable for use by Eagle Tugs in a ground support equipment application.

## 4-1 Putting the Tow Tractor Into Service

### Unpacking and Setting Up

The following directions specify the correct steps that should be taken once you receive delivery of your TT series tow tractor. These steps will ensure that the tow tractor will operate safely.

1. Read this entire manual, paying close attention to the safety requirements laid out in it.
2. During the unloading of your Tractor, you should have noted any shipping damage and reported it to Eagle Tugs and the shipping company. Verify that all components appear to be in order and undamaged.
3. Remove any documentation (including this manual) from where it is secured to the seat. Dispose of the zip ties.
4. Verify correct tire pressure on all tires
5. Fuel the tractor with the correct fuel as specified in section 4-2 of this manual.
6. Your Tow Tractor was shipped with two (TT4-8) or four (TT10-12) removable tie-down rings. If necessary, these rings can be removed using the following directions.  
Note: you will lose the ability to transport the tractor by removing the tie-down rings.
  - TT4 thru TT8 tractors; The rings can be removed by removing the four bolts/nuts that secure the hitch and tie-down ring bracket in place. The hitch then needs to be re-secured using the same bolts and torqued to a value of 85/115 ft-lbs/Nm.
  - TT10 thru TT12 tractors; The rings can be removed by removing the four bolts/nuts that secure the tie-down bracket in place. The hardware does not need to be reinstalled.

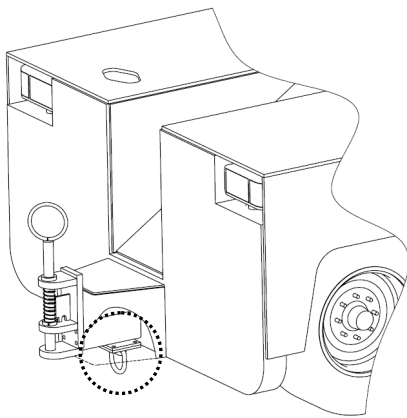

TT10-12 Tie-Down  
Ring Location

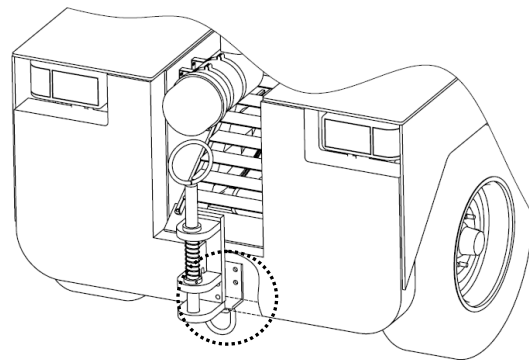

TT4-8 Tie-Down  
Ring Location



### Fuel Requirements

Only use the fuels specified below. Failure to use the indicated fuels could lead to poor performance or unwarranted damage to engine components. As fuel capabilities are subject to change, please refer to [www.eagletugs.com](http://www.eagletugs.com) for the latest up-to-date notices regarding fuels.

Engine	Fuel
Wiscon TME27 Gas	87 Octage Gasoline
Wiscon TME27 LPG	LPG
Yanmar 4TNV98 Tier2	No. 2 Diesel
Yanmar 4TNV98T Tier2	No. 2 Diesel
Yanmar 4TNV98 Tier3/Stage3A	Low Sulfur No. 2 Diesel
Yanmar 4TNV98T Tier3/Stage3A	Low Sulfur No. 2 Diesel

### General Safety

The following safety recommendations are not intended to address every possible safety aspect of operating this vehicle, but rather serve as a guide. Eagle has taken extensive measures to make sure the ALL vehicles are designed and tested to be safe when they leave the factory. Modifications made to the vehicle after it leaves the factory can cause the vehicle to be unsafe. In any situation, common sense and caution should always be applied and is ultimately the owner/operator's responsibility.

This tractor is designed to be a dedicated "WORKING" vehicle. It is not designed for or intended to be used for recreational activities, racing or general "horse play activities". Use for any of these inappropriate activities could result in injury, death or damage to the tractor and surrounding objects.



**Warning: Failure to comply with the following safety precautions can result in serious injury or death as well as equipment damage.**

- Follow all company, facility and OSHA Safety Rules. If you don't have a copy of these, request a copy from your facility management and review them carefully.
- Review carefully and understand the appropriate sections of this manual before endeavoring to start or operate this tractor.
- Be sure that the tractor is equipped with fully functional safety equipment required in the areas it will be operated. Such items as rotating beacons, back-up alarms, etc. are available from EAGLE's Factory or your local EAGLE distributor.



**Warning: All internal combustion engines give off various fumes and gases when running. Do not start or run the engine in a closed or poorly ventilated building where the exhaust gases can accumulate. Avoid breathing these gases as they may contain poisonous carbon monoxide, which can endanger your health or life if inhaled steadily for even a few minutes.**

- Always do the "PRE-OPERATION INSPECTION" before using the tractor (See "CHECKLIST" following this section of the manual).
- Do not begin to operate the tractor if it should have defective lights, horn, brakes, steering or tires. Report irregularities immediately to your supervisor and/or the proper maintenance personnel.
- Never start the tractor's engine while standing on the ground. Start the engine from the operator's seat with the transmission in neutral or park and the parking brake in the "on" position.

- Your tractor's seat/s are equipped with retractable seat belts for your safety. Fasten your seat belt and adjust the seat before starting the engine. Be sure the seat belt is fitted snugly around the hips, not around the waist as failure to do so may cause injury in the event of a collision.
- If your tractor is equipped with a passenger seat, and if it is occupied, be sure that the passenger does not distract you from the safe operation of the tractor. **BE ALERT!**
- You (and any passenger) must always keep your arms and legs within the perimeter of the tractor's frame to avoid injury.
- Keep your foot **ON** the brake pedal and **OFF** the accelerator and release the parking brake before shifting the transmission into gear.
- Before shifting from forward to reverse or reverse to forward, bring the vehicle to a complete stop. Do not shift into gear except when the engine is at idle speed and your foot is on the brake pedal.
- Before dismounting from the tractor, place the transmission in "**PARK**" and apply the parking brake.
- If you have not operated this equipment previously, practice driving and operating it in a safe and clear (not congested) area until you are familiar with all aspects of its operation.
- Keep hands and feet away from moving mechanical parts including tires.
- Avoid wearing loose clothing that might get caught in moving parts.
- Check your path of intended motion for personnel and/or possible obstructions, before proceeding.
- When operating the tractor, be particularly cautious when in congested areas. Be alert near blind corners and always anticipate other equipment and personnel movements. Sound the horn when approaching corners.
- Use particular care to operate the vehicle at a safe speed, commensurate with conditions. Speed should always be reduced when entering a turn to assure complete control of the vehicle and any towed loads. Take all corners wide, especially if towing trailers.
- Speed should always be adjusted to allow for a safe and controlled stop, considering the space available for stopping and the weight of the load being moved. Avoid sudden stops.
- Reduce speed when approaching speed bumps.
- Do not tamper with the engine speed governor.
- Never drive crossways on a slope.
- Avoid operating on bumpy, soft surfaces. Avoid potholes when present.
- Keep clear of the edge of loading docks.

## 5-2 General Usage

### Operator Requirements

The TT series tow tractor is a piece of industrial equipment and has inherent safety risks. As such, the operator of the tow tractor is expected to have a fork truck or similar license, or be otherwise trained in the usage of material handling equipment.

The operator should read this manual fully before operating the tow tractor.

The operator should be familiar with all aspects of the tow tractor before operating it.

### Operator Workstation

Your TT series tow tractor features an ergonomically designed operator's workstation. This is the only operator workstation on the tractor. Do not sit on or stand on the tractor outside of this area.

The operator should be seated with the seatbelt secured when starting or moving the tractor.

The operator (and any passengers) should keep all extremities within the perimeter of the tractor's frame to avoid injury.

The only time it is appropriate to leave the operator's compartment when the tractor engine is running is while the tractor is stopped, the transmission gear selector is in park, and the parking brake is applied.

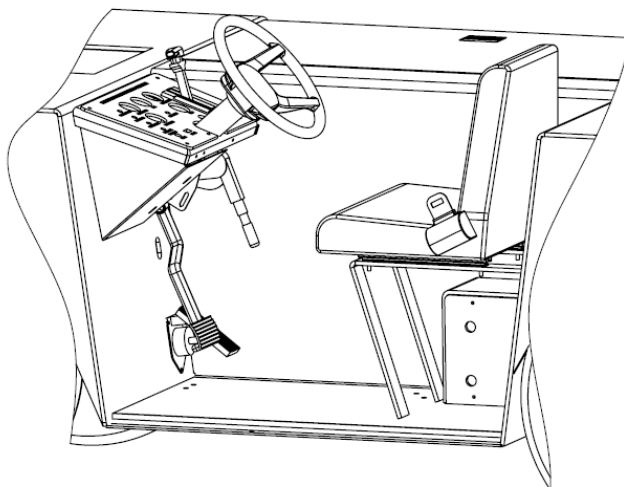

### Pre-Operation Inspection Checklist

The following inspections should be conducted each day prior to the first operation of the tractor. Additional inspections may be required due to unusual operating conditions

### Walk-A-Round Inspection

- Look for evidence around and under tractor for oil, water or fuel leaks.
- Check that fuel cap is securely in place.
- Check tire rims and wheel stud nuts for possible damage.
- Check tires for under inflation, cuts, breaks or excessive wear and remove any objects stuck in treads.
- Wipe clean, if necessary, all lights, mirrors and reflectors.
- Open engine compartment hood and check;
  - Oil and coolant levels.
  - Condition of all drive belts (for cracks or fraying).
  - Condition of all wiring, hoses and tubing for leaks, kinks or excessive wear.
  - If tractor is diesel powered, visually check fuel filters and drain the water if necessary

### Inside Drivers Compartment

- With the transmission in PARK and the hand brake set, start the engine.
- Check oil pressure and voltage gauges to be sure they are indicate a reading in the normal range.
- Check fuel gauge to determine if fuel should be added.
- Sound the horn and test for excessive play in the steering wheel.
- Turn on all lights and flashers. Then exit tractor to verify they are operating properly. If the tractor is equipped with a rotating beacon, check if it is functioning.



**Warning: Keep hands and clothing away from fans, belts, and any moving parts.**

Cab Inspection

If the tractor is equipped with a cab:

- Check that all mirrors are properly adjusted and clean.
- Test windshield wiper .
- Check all windows for cracks or chips. Be sure windows are clean for best visibility
- Check that heater and heater fan are functioning correctly.
- Check defrost fan for proper operation.



**Warning: Any problems noted during inspection should be corrected as soon as possible. Failure to attend to problems promptly could compromise safety and/or the tractor's performance. Do not attempt to make repairs. Contact a qualified mechanic.**

### TT Digital Control Panel:

The TT line of tow tractors equipped with Yanmar 4TNV98 engines also feature a Sauer digital display and control unit provided by Sauer-Danfoss. The Sauer display provides many useful features and benefits to the operator. Below, you will find standard operating instructions for the display.

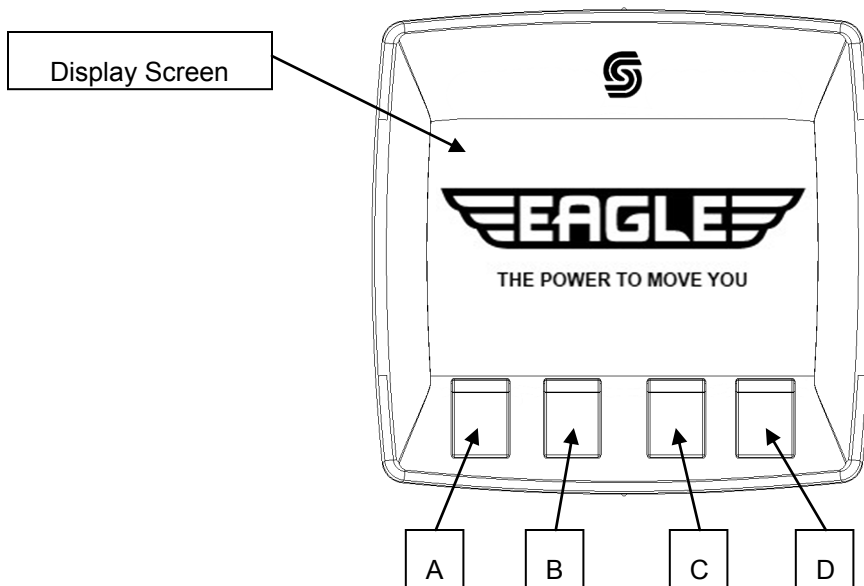

### Starting the unit:

Starting the truck is done with the Sauer display panel. Be sure the transmission is in Park or Neutral and engage the parking brake. Turn the ignition switch to "ON" to provide power to the Sauer display panel.

Once powered up, the Sauer display panel will prompt the user to turn the ignition switch to crank the engine.

**READY TO START**  
USE IGNITION SWITCH  
TO CRANK ENGINE

Hours: 539.6  
Voltage: 13.3  
Fuel: 23%

### Shutting Down the Unit:

Shutting down the unit is as simple as switching the ignition switch to the "OFF" position while the engine is running.

Operation Screen:

The **Operation Screen** is the main screen and provides gauge and other engine/truck operating information. The **Operation Screen** shows the Fuel level (large center gauge), Oil Pressure (upper right), and Coolant Temperature (upper left) as the three analog gauges. Supplemental information is shown as text at the bottom right corner of the display (engine hours, battery voltage, and engine rpm).

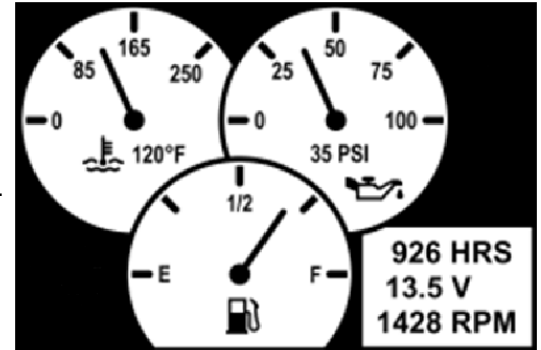

The Operation Screen will also show fault codes and warning and informational messages.

If a fault code appears, take careful note of it before powering down the tractor. The fault code will be reset after restarting.

Supplemental Options:Brightness/Contrast:

Press **D** from the Operation Screen. Use the **A** and **B** buttons to adjust the brightness. Use the **C** and **D** buttons to adjust the contrast.

The display will return to the Operation Screen after 5 seconds without a key press.

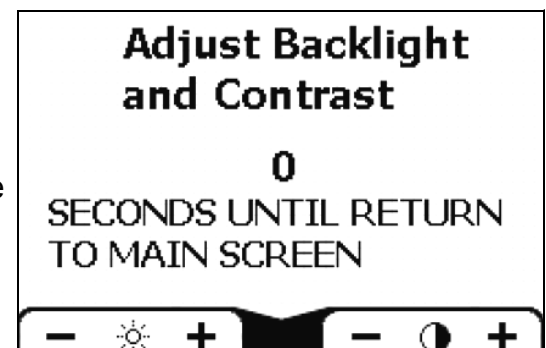
Units:

Press **C** then **B** at the same time for 3 seconds to toggle from Imperial to Metric Units.

Fault Codes:

Press **B** to from the Operation Screen to view the Engine Fault Screen. This will show active and inactive faults that have occurred since the vehicle was turned on. If you are receiving a fault code, take careful note of it before powering down the tractor. All fault history will be reset after restarting.

J1939 ENGINE FAULTS		
(W)	SPN #	0
(P)	FMI #	0
(S)	OC #	0
	TOTAL	0
ACTIVE	▲	▼



### Instrumentation

Familiarize yourself with all instruments on the tractor. Many are designed to alert you to conditions that must be addressed. When operating the tractor, frequently check gauges to insure everything is functioning as it should be and in the normal range.

### Oil Pressure Gauge

The gauge will vary within the normal operating range of 10-50 psi (69-345 kPa) for TME27 engines and 20-60 psi (138-414 kPa) for 4TNV98 and 4TNV98T engines. If the value drops below the normal range when the engine is running, there is a loss of pressure. If this occurs, stop the tractor as soon as possible, shut off the engine and check the oil level. Add oil as necessary. Check for possible causes (leaks) for the low oil pressure. If low oil pressure should reoccur, follow the above directions and contact equipment maintenance personnel to determine cause of recurring low oil pressure.



**Caution: Do not continue to operate the tractor as long as the oil pressure is below the normal operating range. Continued operation may cause severe internal engine damage.**

### Hour Meter

The hour meter indicates the amount of running time on the engine. It is used as a guide as to when preventative maintenance procedures should be done. (See "Preventative Maintenance Schedules" following this section of the manual).

### Voltage Gauge

This gauge indicates the battery voltage available (normally 12-14 volts). After starting the engine, the value should be about 14 volts, which indicates the alternator is working. If the value falls below 12 volts with no accessories operating and the engine running, have the electrical system checked by maintenance personnel. The value may fall below 12 volts at engine idle and accessories operating--shut off all accessories to check that pointer returns to 12 volts or higher while the engine is running. Also by adding a little throttle to increase engine speed, the value should climb back into the correct voltage position.

### Fuel Gauge

The fuel gauge indicates the approximate fuel level in the fuel tank. The reading may fluctuate during starting up, cornering and stopping. It is recommended that the fuel supply be kept at 1/4 or higher levels to prevent any water condensation in the fuel tank from entering the fuel lines.

## 5-5 General Usage

---

### Temperature Gauge

This gauge indicates the temperature of the engine coolant. The temperature will rise to the normal range as the engine warms. If the value moves above the normal range of 225°F (107°C), the engine is overheating. Check for proper airflow through the radiator and that there is not a coolant leak. Running the engine while overheating can cause engine damage.



**Caution: If the engine continues to overheat, have the cooling system checked.**

## Controls

### Ignition Switch (TME27 Engines)

Your tractor is equipped with either a keyless or keyed ignition switch. Both switches are three-position switches-OFF, ON and START (Crank).

- ON POSITION - The fuel pump, electrical system, accessories and fuel-temperature-voltage gauges are activated. The oil pressure gauge will not fully activate until the engine is started.
- START POSITION – This is used to start the engine. The engine will crank until you release the ignition switch. When the ignition switch is released in the start position, you must turn the switch to the "OFF" position first before returning to the start position. This is to prevent trying to start the engine when it is already running (anti-restart protection).
- OFF POSITION - This is used to shut down the engine and turn all electrical power off (including accessories). Never leave the tractor unattended with the engine running or the ignition switch in the "ON" position, as this can result in a run-down battery.

### Ignition Switch (4TNV98 Engines)

Your tractor is equipped with either a keyed or no ignition switch. The switch provides power to the H30 which is used to start the engine. If the case that there is no ignition switch, the H30 is always connected to a power supply.

### Headlight switch

The headlight switch is an on/off type. There is no hi/low beam control position.

### Heat Temperature Control (Option)

The heat temperature control is a push/pull control cable and is used to adjust the air temperature from the heater in a cab. Pull up to set at desired temperature. Push down to turn heat off.

### Heater Fan Control Switch (Option)

The heater fan switch has three positions, OFF, LOW and HIGH.

### Windshield Wiper Switch (Option)

The windshield wiper switch (located on the wiper motor) has an on/off position. The wiper has only one speed.

### Defrost Fan Control (Option)

The defrost fan motor has a switch built in. The switch has three positions-OFF, LOW and HIGH.

### Starting & Shut-Down Procedures

Never start the tractor's engine while standing on the ground. Start the engine from the operator's seat with the transmission in neutral or park and the parking brake in the "on" position.

Your tractor's seat(s) is/are equipped with retractable seat belts for your safety. Fasten your seat belt and adjust the seat before starting the engine. Be sure seat belt is fitted snugly around the hips, not around the waist as failure to do so may cause injury in the event of a collision.



**Warning: Seat belts may not offer the operator protection in the event of a rollover. The known incidents of a rollover are extremely rare and may occur in situations of operator misuse. Uses of any vocational equipment should be strictly limited to it's intended operation.**

Your tractor may be equipped with an operator's seat containing a safety pressure switch and/or an operator floor mat containing a safety pressure switch (depending on model and options). If it is, it will automatically shut the engine down anytime the transmission is in gear and the operator is not present in the operator's workstation.

### Gasoline/LP Tractors (TME27)

Be sure that the transmission is in "Park" or "Neutral".

1. Turn ignition switch to the "ON" position.
2. Depress accelerator pedal once and release.
3. Turn ignition to the "crank" (Start) position to activate the starter motor. Do not crank the engine more than 10 seconds if it doesn't start. If engine does not start, turn ignition switch off. Turn ignition switch to "on" position. Depress accelerator pedal twice and release. Turn ignition to the "crank" position to activate the starter motor.
4. As soon as the engine starts, release the ignition switch and allow it to return to the "on" position to avoid damage to the starter and/or flywheel gear teeth.
5. Allow the engine to warm up for a minute or two.
6. Read all instrument panel gauges to verify they are all within the normal operating ranges defined previously under "Instrumentation".

Diesel Engine (4TNV98)

Be sure the transmission is in "Park" or "Neutral".

1. Turn ignition switch (if equipped) to the "ON" position.
2. See "Starting the Unit" in section 5.6.
3. Allow the engine to run at idle speed approximately 6 minutes (1/10 of an hour on the hour meter) to circulate and warm engine oil to a safe operating temperature.
4. To shut down the engine, reduce engine speed to idle if the engine is hot. Allow the engine to idle for several minutes to cool to below 195 degrees. Then turn off the H30 display and turn off the key switch (if equipped).



**Warning: External starting fluids should not be used in a diesel engine air intake system. The use of these fluids will cause severe internal engine damage.**

## 5-8 General Usage

### Transmission Operation

The transmission is controlled by a "lever type" gearshift located in the instrument panel or console. The control has six selector positions- P (Park), R (Reverse), N (Neutral), D (Drive), 2 (Second) and 1 (First). In entering or leaving a gear position, the lever must be moved past a gate. To do this, place the palm of your hand on the top of the selector lever and reach under with your fingers and grip the release mechanism and pull up (or squeeze). Shift to the desired position and release the selector.

1. Keep your foot ON the brake pedal and OFF the accelerator and release the parking brake before shifting the transmission into gear.
2. Before shifting from forward to reverse or reverse to forward, bring the vehicle to a complete stop. Do not shift into gear except when the engine is at idle speed.
3. Before dismounting from the tractor, place the transmission in "PARK" and apply the parking brake.

### Parking Brake

The parking brake is operated by hand lever action. By pulling back on the lever, you activate and set the brake. Pushing forward will release the brake. The brake is adjustable for braking pressure by rotating the knob on the end of the handle lever. A clockwise direction is used to increase the brake holding pressure and counter clockwise to reduce the pressure.

All trucks feature a safety system to protect the parking brake from accidental misuse. Depending on engine type, either the accelerator pedal will not respond when the parking brake is engaged, or the engine will shut off when both the parking brake is engaged and the truck is shifted out of Park or Neutral.

### Foot Brake

The foot brake is power assisted and should be applied with a steady and firm downward pressure. If the power assist should fail, the brakes will still operate mechanically but will require increased foot pressure. Always anticipate that you may have to stop unexpectedly.

Speed should always be adjusted to allow for a safe and controlled stop. Adjust your speed based on the surface conditions, the space available for stopping and the weight of the load being moved. Be aware of your surroundings. Always be prepared to stop and avoid sudden stops.



**Caution: If driving on wet or slippery surfaces, lower speed and allow for more stopping distance. Do not spin the wheels when starting up as this may cause damage to the drive mechanisms.**

Your tractor is equipped with both front and rear wheel brakes. The front and rear brakes operate on a dual system-- if one set should fail the operation of the other set will continue. The system has an emergency back up of up to three hard applications of the brakes should both systems fail.

### Parking

Every time you park, apply the hand brake, turn the engine off, turn the ignition switch to "off" (if equipped) and return the transmission shift lever to neutral or park position.

Do not park where you may block other vehicles paths or movement by emergency vehicles.

## 6-1 Instructions for Safe Towing/Pushing Load

### Moving Loads

Maximum capacity towing or pushing of loads shall be done with the transmission selector lever in 1(first) or REV (reverse) gears.



**Caution: Pushing or towing loads in D (Drive) can cause transmission failure**

### Load Towing Safety

If towing a load, check to see that:

- The towed load is securely connected to the hitch of the tractor. Be sure hitch is locked/fastened into the closed position.
- The towed cargo load is secure and within the exterior frame of the vehicle that is carrying the load.
- For maximum tractor and load control and stability, as well as towing power, be sure the tongue of the trailer is parallel to the ground when connected to the tractor's hitch.
- Watch the trailer's rear swing clears any obstructions when cornering.

### Load Pushing Safety

If pushing a load:

- Be sure the tractor is designed for and intended to be used to push the load.
- If using the tractor for "pushback" of an aircraft, be sure the tow bar is securely fastened to both the aircraft and the tractor and the tractor hitch is in the locked position.



### Emergency Towing

If it should be necessary to tow the tractor to a location for maintenance service, be sure the following procedures are followed:

- Make sure the parking brake is released and the transmission gearshift lever is in the "N" (Neutral) position.
- "ALL WHEEL DRIVE" tractors must have the drive shafts removed before towing. Plug the drive shaft openings to minimize loss of fluid.
- "REAR DRIVE ONLY" tractors, the rear wheels can be raised and it can be towed on its front wheels. If it is to be flat towed, the drive shaft must be removed.
- "ANY TRACTOR" towed on its front wheels must have the steering wheel clamped in the straight ahead position.



**Caution: Replace lost transmission fluid after reinstalling the drive shafts that were removed for towing.**



**Warning: Before working underneath the tractor, be sure jack stands are secure and positioned correctly (perpendicular to the floor) with no tilt.**



**Warning: If you will be working under the tractor, never do so when alone. Be sure someone else is close by in case of an emergency.**



**Warning: If using a hydraulic or air operated lift, always check the safety support or lock is in position before going underneath the tractor.**

### Tie Down Procedure

For long distance travel, the TT-series tow tractor can be transported by trailer. When transporting the tow tractor, please use the following tie-down procedure. This will ensure that the tractor is securely fastened and will prevent damage to the tractor.

- 1) Position tractor on trailer, put transmission selector in Park and set Parking Brake.
- 2) Use correctly sized load chains to secure the tractor to the trailer side tie downs - Do not use load straps.
- 3) Run chain through the tie-down rings located behind the E-hitches.
- 4) Take both ends of the chain out and down away from the tractor and tighten as required to secure the tractor.
- 5) Note: chains must not touch front or rear of tractor. Chain contact with the tractor is with the tie-down rings only.
- 6) Do not top load anything on the tractor.
- 7) Do not run straps or chain across the top of the tractor.

### Maintenance Operator Requirements

Only trained and qualified mechanics familiar with ground support equipment should undertake repairs on the TT series tow tractor.

The maintenance operator should read the operator's manual and the service manual fully before performing maintenance on the tow tractor.

### Repairs Safety

ONLY a trained and qualified mechanic for this type of equipment should undertake repairs to this tractor. Before undertaking any repair, the mechanic MUST read and understand the "SAFETY" and "OPERATING PROCEDURES" sections of this manual. All safety recommendations and rules MUST be followed.

General Safety Guidelines

- Always stop the tractor, turn the engine off, put in "Park" and apply the parking brake when making any adjustments or servicing the unit.
- Never refuel the tractor when the engine is running.
- **DO NOT SMOKE WHEN REFUELING.**
- Do not over fill the fuel tank. Do not fill beyond bottom of fuel filler screen. Clean off any spilled fuel immediately.
- Keep fuel stored well away from open flames, possible sparks or sources of excessively high temperatures.
- Do not ever remove the radiator cap when the engine is hot, as serious burns may result. Always check coolant level and add coolant at the overflow reservoir.
- Avoid touching a hot engine, exhaust, coolant pipes or hydraulic components as serious burns may occur.
- This tractor comes factory equipped with a sealed "maintenance free" battery. Do not endeavor to service the battery.
- When connecting or disconnecting battery cables, always first remove the cable on the negative terminal (-) and when reconnecting, replace it last. This will prevent sparks from accidental grounding.
- **PREVENT BATTERY EXPLOSIONS.** Do not smoke near the battery. Fumes from batteries are explosive. Keep away from all sparks, open flames etc... Remove bracelets; watch bands etc. prior to installing, removing or servicing a battery. Do not short the battery terminals.
- **AVOID ACID BURNS.** The battery acid is poisonous and is strong enough to burn skin, eat holes in clothing and cause blindness if splashed in the eyes. If battery acid is spilled or splashed, always immediately wash your skin and clothing. Apply lime or baking soda to help neutralize the acid. Seek medical assistance.

### Important Safety Notice

Appropriate service methods and proper repair procedures are essential for the safe, reliable operation of all industrial engines as well as the personal safety of the individual performing the work. This Service Manual provides general directions for accomplishing service and repair work with tested and effective techniques. Following them will help assure reliability.

There are numerous variations in procedures, techniques, tools and parts for servicing equipment, as well as in the skill of the individual doing the work. This Manual cannot possibly anticipate all such variations and provide advice or cautions as to each. Accordingly, anyone who departs from the instructions provided in this Manual must first establish he compromises his/her personal safety, and/or the equipment integrity by his/her choice of methods, tools or parts.

### Warnings

The following list contains some general WARNINGS that you should follow when you work on equipment:

- Always wear safety glasses for eye protection.
- Use safety stands whenever a procedure requires you to be under the equipment.
- Be sure that the battery is disconnected from the truck using the battery disconnect, unless otherwise required by the procedure.
- Set the parking brake (if equipped) when working on the equipment. Place wood blocks (4" x 4" or larger) to the front and rear surfaces of the tires to provide further restraint from inadvertent equipment movement.
- Operate the engine only in a well-ventilated area to avoid the danger of carbon monoxide.
- Keep yourself and your clothing away from moving parts when the engine is running, especially the fan and belts.
- To prevent serious burns, avoid contact with hot metal parts such as the radiator, exhaust manifold, tail pipe, catalytic converter and muffler.
- Do not smoke while working on the equipment.
- To avoid injury, always remove rings, watches, loose hanging jewelry, and loose clothing before beginning to work on the equipment. Tie long hair securely behind the head.
- Keep hands and other objects clear of the radiator and blades. Electric cooling fan (s) can start to operate at any time by an increase in under hood temperatures, even though the ignition is in the OFF position. Therefore, care should be taken to ensure the electric cooling fan(s) are completely disconnected when working under the hood.

Preventative Maintenance Schedule

Diesel Engine (4TNV98)

System	Description of Check/ Service <b>X</b> -Check * Requires Service <b>**</b> Contact your local Yanmar distributor or dealer	Operational Hours								
		Daily	50	250	500	750	1000	1250	1500	2000
Engine Oil	Engine Oil and filter <b>*first 50 and every 250 hours thereafter</b>	X	*	*	*	*	*	*	*	*
Transmission	Transmission Fluid	X								*
Steering	Power Steering Fluid	X								
	Steering Linkage				X		X		X	X
Cooling System	Coolant Level Check <b>X</b> Flush *	X					*			*
	Check & Clean Radiator Fins <b>*every 50 hours</b>		*							
	Coolant Hoses		X	X	X	X	X	X	X	*
	Belts		X	X	X	X	X	X	X	X
Fuel System	Fuel System Leak Check		X	X	X	X	X	X	X	X
	Fuel Filter <b>*every 500 hours</b>				*		*		*	*
	Drain Water/Fuel Separator <b>*every 50 hours</b>	X	*							
	Clean Water/Fuel Filter <b>*every 250 hours</b>			*	*	*	*	*	*	*
	Lubricity Filter <b>*every 250 hours</b>			*	*	*	*	*	*	*
Air Cleaner	Air Cleaner Element <b>*every 500 hours</b>				*		*		*	*
Engine Compartment	Engine Rubber Mounts		X	X	X	X	X	X	X	X
	Lap Intake/ Exhaust Valve Seats						**			
	Adjust Intake/ Exhaust Valve Clearance						**			
	Check & Adjust Governor Lever & Engine Speed Control <b>*every 250 hours</b>	X		X	X	X	X	X	X	X
	Inspect Crankcase Breather System Valve Cleaning								**	
	Inspect, Clean & Check Injection Nozzles								**	
Electrical	Electrical Wires and Connections		X	X	X	X	X	X	X	X
	Battery Cables	X								
Throttle	Throttle Controls		X	X	X	X	X	X	X	X
Brake System	Brake Fluid	X								
	Brake Pads (Front)				X		X		X	X
	Drum Brake Lining (Rear)				X		X		X	X
	Brake Lines and Hoses				X		X		X	X

Diesel Engine (4TNV98), Continued

System	Description of Check/Service	Operational Hours								
		Daily	50	250	500	750	1000	1250	1500	2000
	<b>X</b> -Check * Requires Service ** Contact your local Yanmar distributor or dealer									
Suspension	Suspension U-Bolts 110-120 FT LBS		*							
	Drive Axles				*		*		*	*
	Axle Shaft U-joint				*		*		*	*
	Driveshaft			*	*	*	*	*	*	*
Tires	Rotate Tires *every 500 hours				*		*		*	*

This section below has been added to for your record keeping convenience

Date Service Performed	
Tug Serial Number	
Tug Hours	
Technician	

Gasoline Engine (TME27)

NO	Description of Check/Service	Operational Hours						
		Daily	50	100	250	500	750	1000
	<b>X-Check * - Requires Service</b>							
1	Engine Oil and filter <b>*first 50 hours and every 100 hours thereafter</b>	x	*	*				
2	Transmission Fluid <b>*every 500 hours</b>	x				*		*
3	Power Steering Fluid	x						
4	Brake Fluid	x						
5	Coolant Level	x						
6	Fuel Filter <b>*every 250 hours</b>				*	*	*	*
7	Oil Leak Check	x						
8	Engine Rubber Mounts		x	x	x	x	x	x
9	Inlet & Exhaust Pipes to Manifold		x	x	x	x	x	x
10	Throttle Controls		x	x	x	x	x	x
11	Coolant Hoses		x	x	x	x	x	x
12	Belt Drives		x	x	x	x	x	x
13	Fuel System Leak Check		x	x	x	x	x	x
14	Electrical Wires and Connections		x	x	x	x	x	x
15	Suspension U-Bolts		*					
16	Battery Cables			x				
17	Air Cleaner Element <b>*every 250 hours</b>				*	*	*	*
18	Brake Pads (Front)					x		x
19	Drum Brake Lining (Rear)					x		x
20	Brake Lines and Hoses					x		x
21	Flush Cooling System					*		
22	Adjust Valve Tappet Clearance					*		
23	Spark Plugs <b>*every 1000 hours</b>							*
24	Replace O2 Sensors <b>*every 1000 hours</b>							x
25	PCV valve					x		x
26	Drain EPR Assembly <b>*every 500 hours</b> (LPG Fueled Engines Only)					*		*
27	Rotate Tires <b>*every 500 hours</b>					*		*



## Daily Operator Responsibilities

### Proper Fluid Checks

#### Engine Oil

Check engine oil with the unit on a level surface, the key in the “OFF” position (if equipped), the H30 display off (if equipped), the shifter position in “PARK” and parking brake applied. Open side access door or hood depending on engine configuration. Remove dipstick from crankcase, wipe it with a cloth. Insert it fully and take out it gently again. Check the oil level by the marks on the dipstick. The oil level must be between the “Max” level and the “Min” level. DO NOT OVERFILL.

#### Coolant

DO NOT remove recovery tank cap or check coolant level while engine is hot! With engine cool, the key in the “OFF” position (if equipped), the H30 display off (if equipped), the shifter position in “PARK” and the parking brake applied, open hood, set hood prop and look at left side of recovery tank. The reservoir tank is translucent, so the fluid is readily visible without removing the cap. Fluid level should be at the “Cold fill level”.

#### Transmission Fluid

With unit in park and parking brake set in the “ON” position, start engine. Open side access door. Remove dipstick from transmission case, wipe it with a cloth. Insert it fully and take it out gently again. Check the fluid level by the marks on the dipstick. The transmission fluid level must be between the “Max” level and the “Min” level on the dipstick. DO NOT OVERFILL.

#### Brake Fluid

Check brake fluid with the unit on a level surface, the key in the “OFF” position (if equipped), the H30 display off (if equipped), the shifter position in “PARK” and parking brake applied. Open hood, set hood prop and locate master cylinder reservoir. Remove spring clips and take off lid. Brake fluid level should be at the top of reservoir.

#### Power Steering Fluid

Check power steering fluid with key in “OFF” position (if equipped), the H30 display off (if equipped), the shifter position in “PARK” and the parking brake applied. Open hood, set hood prop remove cap from power steering reservoir. Fluid level should be between the arrows on the indicator stick. DO NOT OVERFILL.

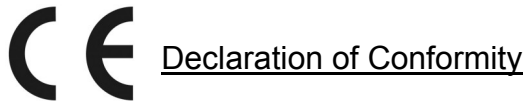
Declaration of Conformity

Eagle Industrial Truck, LLC  
26111 Northline Road  
Taylor, MI 48180

Eagle Tugs certifies that the TT-series of Aircraft Tow Tractors (including TT4 thru TT12 tractors) are in conformance with the following European safety directives.

Machinery Directive 2006/42/EC

Non-road Mobile Machinery Exhaust Emissions 97/68/EC

CE Marking Directive 93/68/EEC

Electromagnetic Compatibility Directive 2004/108/EC

Relevant documentation is maintained by Eagle Industrial Truck and can be furnished upon request. Conformance was certified on 12/28/2009 at Eagle Tugs in Taylor, MI.

A handwritten signature in black ink, appearing to read 'Phil Brewer', is positioned above the printed name.

Phil Brewer  
Engineering Manager  
December 28, 2009

Safety Procedure Review Signature Sheet

By signing below you are verifying that you have read and understand the contents of this manual.

Date:

Printed Name:

Signature:

_____	_____	_____
_____	_____	_____
_____	_____	_____
_____	_____	_____
_____	_____	_____
_____	_____	_____
_____	_____	_____
_____	_____	_____
_____	_____	_____
_____	_____	_____
_____	_____	_____
_____	_____	_____
_____	_____	_____
_____	_____	_____
_____	_____	_____

